



140 3rd Street South
Dassel, Minnesota 55325-0707
Phone: 800-328-8996 Fax: 800-789-1882
american-time.com
© American Time

TITLE: Setting/Verifying the 12:00 (Home) Position on AllSync Plus Clocks - WWVB

INSTRUCTION SHEET: 1540

REVISION: 02

EFFECTIVE DATES: 01-2007 to 04-2012

If the hands on your AllSync Plus clock are consistently off a few minutes from your master, your hands have moved from their home position. This could have been caused by rough handling when the clocks were shipped to you, by the clock being dropped or if the hands have been manually moved. To verify that your hands are in the correct “home” position, follow the steps below.

Warning: To prevent electrical shock, cover circuit board inside dust cover with non-conducting material while dust cover is separated from clock back.

SETTING/VERIFYING THE 12:00 (HOME) POSITION:

1. Unplug clock
2. Remove the two nuts holding dustcover on
2. Lift dustcover up and unplug wires going into side of movement
3. Remove movement sticker, “Do Not Install Battery” label and battery cover from the back of the movement
4. Reverse a battery 10 seconds and remove (You will need to supply your own “AA” alkaline battery)
5. Turn rotary switch to DST
6. Press tab down and hold
7. Re-insert battery correctly, move switch slowly to ST & back to MT
8. Release tab
9. Clock will fast run to 12:00 and stop
10. If hands are off, remove and re-position, see “Positioning Hands”
11. If hands are on 12:00, hand position is o.k., replace sticker
12. Reverse battery 10 seconds, **remove battery** and verify the rotary switch is on MT
12. Plug wires back into side of movement, yellow & green wires up
13. Reinstall battery cover and label
14. Re-install dustcover
15. Plug clock back in

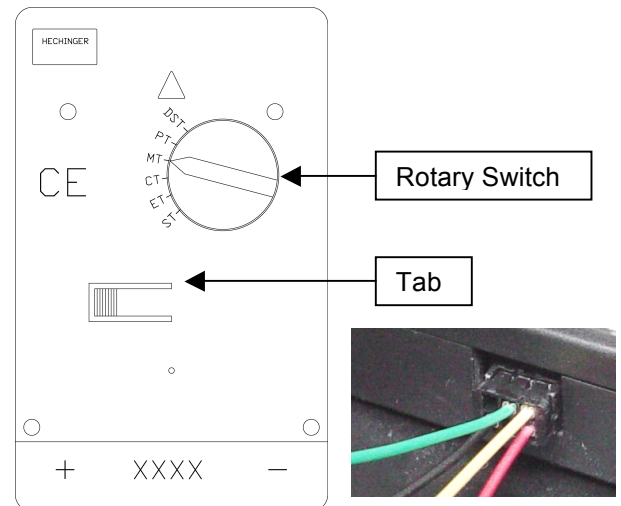

POSITIONING HANDS: (“SETTING/VERIFYING THE 12:00 (HOME) POSITION” must be done first)

1. For plastic clocks hold the case with your hands at the 03:00 and 09:00 position and squeeze until the lens pops out
2. For metal clocks loosen the screws on the bezel clips and remove clock/backplate from the bezel
3. If the sweep hand is off, pull the sweep straight off and re-align to the 12:00 position
4. If the minute hand is off, gently reset to the 12:00 position. (Note: The sweep hand may move when you move the minute hand, this is o.k.)
5. If the hour hand is off you may have a different problem, call American Time for assistance before trying the realign
6. Replace the lens on plastic clocks and replace clock/backplate on metal clocks
7. Reverse the battery 10 seconds, **remove battery** and verify the rotary switch is on “MT”
8. Replace sticker and plug wires back into side of movement, yellow and green wires up
9. Reinstall battery cover and label
10. Reinstall dustcover
11. Plug clock back in

After the AC power is installed, the sweep hand should start to tick in about 10 seconds. The sweep will tick once every 2-3 seconds. The clock should start to correct about 5 minutes later and may take up to 15 minutes to correct to the time on your master. **Important: The rotary switch should be set to “MT” no matter what time zone you are in.**