

Configuration

Configuring Clocks to the inCloud Portal - Browser Method

1. Navigate to the inCloud portal: incloud.american-time.com
Log in using the credentials supplied in the welcome e-mail from American Time.
2. Click on the green "Setup New" button in the PoE Devices bar on the Device List page.
This will open the Setup Network Device List, which will list all the clocks assigned to your site by American Time.
3. Find the clock's MAC address and provide a Title and (if desired) description for the clock.
Repeat this for each clock in the list.
 - The MAC address can be searched using the last five characters of the address including the colon (for example, AA:11) in the search bar.
4. Once this is complete, all clocks will be listed under the Device List. To access this, click on Devices in the site menu.
5. The clocks will remain in a semi-provisioned state until they report in to the portal. As long as the clocks have not yet been powered up, this should occur once power is connected. Otherwise, this may take up to 15 minutes to occur.

The inCloud Management Portal is a fast and intuitive tool for setting up, monitoring and managing American Time products. Get your devices up and running more quickly, efficiently manage their status, and easily make changes. inCloud includes features such as:

- Indicators for clock status and time sync
- Time server management
- Brightness, 12/24-hour display, and other settings and controls
- Default and custom configuration setups, to maintain consistent settings across all clocks

With the inCloud management portal you can set up, monitor and manage your American Time network clocks easily and from anywhere.

incloud.american-time.com

Adjustments via Network Clock Connect

NOTE: All modifications to settings should be performed on the inCloud Management Portal. Network Clock Connect should only be used for flush clock customers who are not using inCloud.

1. Download **Network Clock Connect**. Find it online: american-time.com
Navigate to: [SUPPORT](#) > [PRODUCT DOCUMENTATION](#) > select [FIRMWARE](#) > [SEARCH](#)
Click on **Network Clock Connect**.
The software will automatically download. It is also available from the optional USB Drive (H004167B-POE, purchased separately).
2. Install Network Clock Connect application – Password = clock4u (default)
3. Network Clock Connect will allow you to configure:
 - Network address settings
 - Time Synchronization settings
 - Daylight Saving Time settingsFor more details, reference the **PoE Analog and Global Series Digital Manual**.

Flush-Mount PoE Digital Clock Quick Start Installation Guide



Please read this first!

If this is your first installation or you have questions at any time during this process, please call American Time toll free at **800-328-8996**.

Introduction

American Time flush-mount digital clocks are multi-function corrective clocks, using a Power over Ethernet (PoE) connection to both power the clock and provide a network connection for correcting the time via Simple Network Time Protocol (SNTP). These clocks use the correction protocol to continuously update the time and perform adjustments for Daylight Saving Time.

6-digit flush mount clocks can be used with the optional Timer Control Station (TCS) to perform Elapsed Time Indicator (ETI) and Code Blue functions. Instructions on controlling the ETI and Code Blue features are covered in the TCS documentation.



Safety

WARNING: Hazardous voltage in electrical equipment can cause severe personal injury or death. Inspection, installation, and preventive maintenance should only be performed on equipment to which power has been turned off, disconnected and electrically isolated so no accidental contact can be made with energized parts.

CAUTION: This equipment contains electronic devices that are sensitive to static electric charges. To guarantee protection for the circuitry of this unit, it is required that electrostatic handling precautions be observed when installing or repairing this equipment. Any technician or other personnel working on this unit must wear a static grounding wrist strap or similar device to provide protection of sensitive components.

american time

Integrated Solutions

phone: 800-328-8996

online: american-time.com

fax: 800-789-1882

mail: 140 3rd St. So.; PO Box 707, Dassel, MN 55325-0707

Specifications

	PoE
Weight	6.5 lbs (3 kg)
Box Dimensions	12.625" x 7.325" x 3.5" WxHxD (32 x 18.6 x 8.9 cm)
Faceplate Dimensions	13.5" x 8.5" WxH (34.3 x 21.6 cm)
Code Blue Current	3.0mA maximum at 12-30VAC/VDC
Operating Temperature	30°-104°F (0°-40°C)
Humidity	95% relative humidity at 86°F (30° C) maximum, non-condensing
Display Modes	12-hour or 24-hour, user-configurable
Accuracy	±1 second
Certifications	Electromagnetic Emissions EN 55032:2012/AC:2013 Class B FCC 15.107:2018 Class B FCC 15.109:2018 Class B ICES-003:2016 Class B

	Power Consumption (red digits)	
	Average	Max
2.5" 6-digit	6.5W	8.0W
4" 4-digit	5.5W	7.0W

General Maintenance

American Time digital clocks require minimal maintenance. Cleaning should be done with nothing more than a microfiber towel, moistened with water or a mild alcohol solution. No abrasive materials should be used to clean the clock, as it will result in scratching of the case or lens.

Avoid contact with the internal components of the clock when unpacking or preparing for installation, or if the clock is disconnected after installation. Contact with the internal components when the clock is not grounded can result in electrostatic discharge, which could damage the clock.

Installation

The flush-mount digital clock is designed to be mounted into a wall cavity, similar to a single or double gang box. Ensure that installation conforms to the National Electrical Code and local wiring codes.

NOTE: If installing the clock to be used with a Timer Control Station, the clock and TCS must be no more than 30-ft apart.

CAUTION: Electric Shock Hazard!
Ensure that NO electrical power is present on any wire before installation.

1. Remove the four sheet metal screws (C) that hold the cover assembly (B) and enclosure base (A) together. Be sure to keep the sheet metal screws for reassembly.
2. Mount the enclosure base (A) into the wall by attaching the side of the back box to a stud. Opening is 12.75" x 7.75" x 3.625".

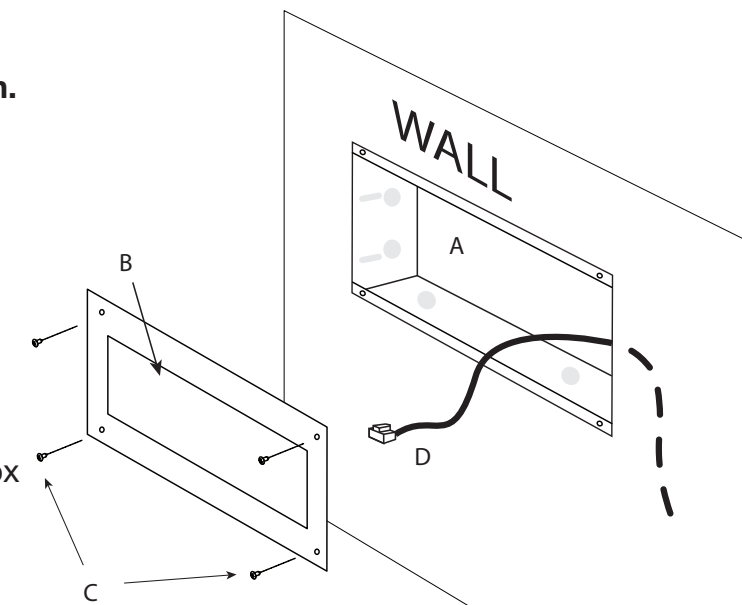

If you are installing a Timer Control Station, proceed to Step 3. To finish clock installation without a Timer Control Station, proceed to Step 6.

3. Pull the wiring from the Timer Control Station through the knockouts in the enclosure.
4. Connect the Timer Control Station wiring to the provided terminal plugs. See wiring detail in the ATSTCS documentation for detailed wiring information.
5. Connect the terminal plug(s) to the terminal blocks on the clock as described in the ATSTCS documentation.
6. Pull the CAT 5 or higher Ethernet cable (D) through a knockout in the enclosure.
7. Connect the Ethernet cable to the RJ45 jack on the clock's circuit board. The clock should power on and obtain a connection, displaying a time within 45 seconds.
8. Re-attach the cover assembly (B) to the enclosure base (A) using the sheet metal screws (C) removed in Step 1.