



Quick Setup Guide

for SiteSync IQ® GPS Plus Wired Clock System

Follow these instructions, in the order shown, for quick setup of your wired system. For more detailed instructions, refer to the SiteSync IQ Installation & Operation Manual supplied with your system.

1 Choose location and install system controller and GPS receiver.

- Place the GPS receiver outside, mounted parallel to the horizon, with a clear view of the sky and with the label facing up. The included mounting bracket allows for mounting on the side of a building or other structure where there is no excessive roof overhang.
- Place the System Controller indoors.
- Locate near an electrical outlet (120vac).

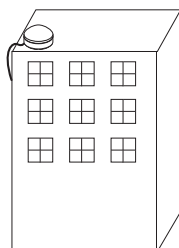

2 Mount system controller into a 19" server rack.

- Place four (4) screws (not included) into the rack mount ears as shown.

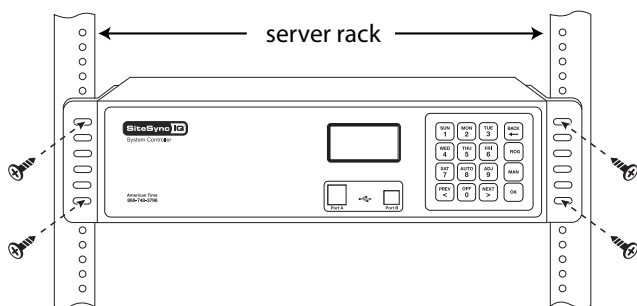

3 Connect cables to system controller.

Note: If your system controller supports more than one sync option, refer to the SiteSync IQ Installation & Operation Manual for detailed instructions.

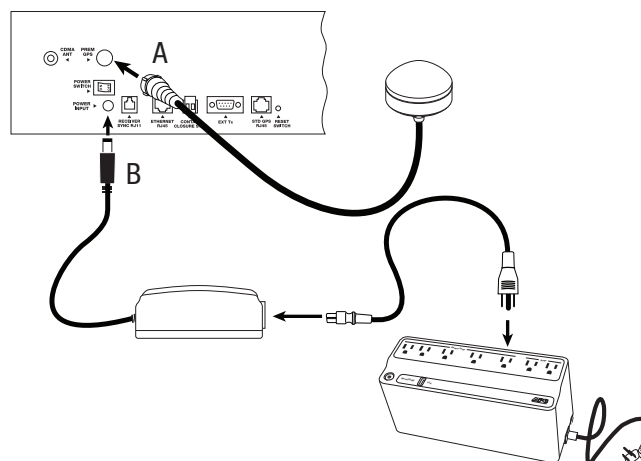

H006238

- Connect GPS receiver cable to PREM GPS port.
- Connect power supply (connected to surge protected 120vac outlet) to Power Input port (American Time & Signal Co. recommends using surge protector/battery backup unit H006238 shown).

4 Turn on the power to the system controller unit and press **SUN 1** to use the Setup Wizard.

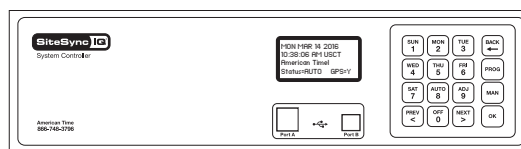

- Enter a 4 digit User Lock or enter 0000 to disable this feature. Press **OK**. **Tip:** Record this lock code in your User Manual.
- Enter a 4 digit Service Lock or enter 0000 to disable this feature. Press **OK**. **Tip:** Record this lock code in your User Manual.
- Select local time zone by using the **PREV** **NEXT** keys. Press **OK**.
- Press **AUTO 8** to select automatic DST or **OFF 0** to disable DST. Press **OK**.
- Press **SUN 1** for 12-hour mode - AM/PM (1:00 PM). Press **MON 2** for 24-hour mode - Military (13:00).
- To confirm proper set up, press **AUTO 8** to sync.
 - If successful, "GPS Sync Successful" will display.
 - If not successful, "GPS Sync Failed" will display. Refer to the troubleshooting guide.
- "Setup Wizard Successfully Completed" will display.

The system controller should now show the correct time and date.



140 3rd St. So. PO Box 707
Dassel, MN 55325
Phone: 800-328-8996
Fax: 800-789-1882
american-time.com

5 SiteSync IQ Terminal Block

For wiring your SiteSync IQ system controller, reference your SiteSync IQ Installation and Operation Manual.

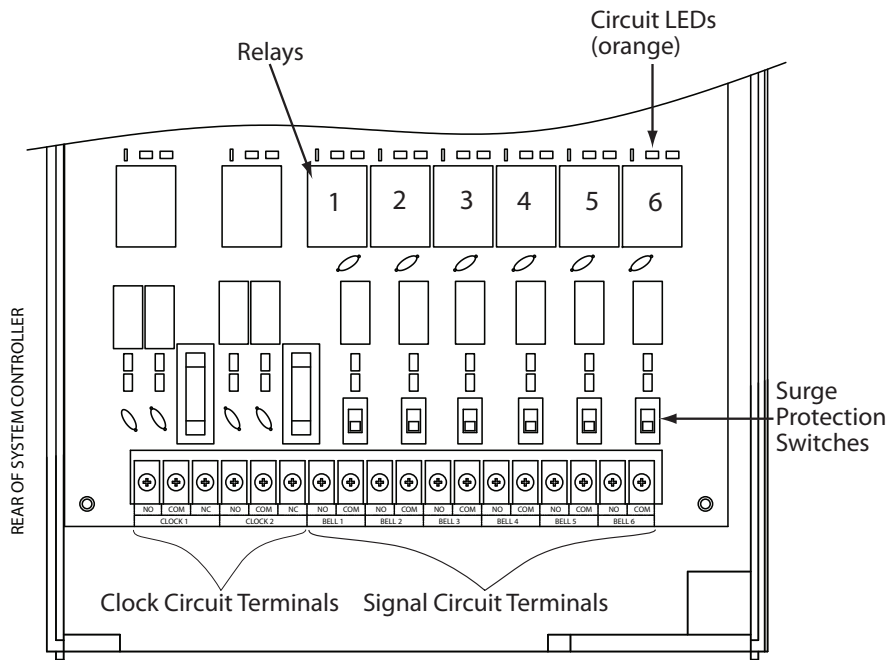

Your SiteSync IQ system is now set up for proper operation. For information on other features, see the SiteSync IQ Installation and Operation Manual that was included with your unit. If you have any questions or problems that cannot be resolved by following the steps in the Troubleshooting Guide, please contact Technical Support at American Time - 866-748-3796.