

STI THERMOSTAT PROTECTOR



STI-9110



STI-9115

PRODUCT OVERVIEW

Molded of polycarbonate material, these protective covers are recommended for areas where abuse to a thermostat is a problem. This may include vandalism, accidental damage or costly, annoying tampering by employees and others. Especially useful where thermostats are located in public areas, the devices are easy to install. STI-9105 and STI-9100 are available in smoke color and clear polycarbonate. Holes in the frame allow air to circulate freely for proper operation of protected thermostats or energy sensors. An interior wall on the frame prevents objects from entering the cover.

THREE YEAR GUARANTEE ON COVER

As all STI polycarbonate covers, these tough units are backed by a three year guarantee against breakage in normal use. The Thermostat Protectors are shipped complete with all mounting hardware.

KEY FEATURES

General Information

- Offers excellent protection against tampering, abuse and accidental damage without affecting operation of the thermostat.
- Includes a lock and key assembly (excludes STI-9115).
- Three year guarantee against breakage of polycarbonate in normal use.

Design

- Holes in the frame allow air to circulate freely.
- Includes a lock and key assembly (excludes STI-9115).

Construction

- Inner wall construction prevents tampering with dials and levers (excludes STI-9115).

Installation

- Easy and quick installation.
- Shipped complete with anchors and screws.
- Typical working properties of polycarbonate are -40° to 250°F (-40° to 121°C).

Options

- Models available for flush and surface mounted applications.
- Spacers available to accommodate exposed conduit.
- STI-9105 and STI-9100 available in smoke color and clear.



For more information, call 1-800-888-4784 (4STI) or visit www.sti-usa.com



**Safety Technology
International, Inc.**

STI Thermostat Protector

Dimensions and Technical Information

MODELS AVAILABLE

Thermostat Protector, Mini with key lock - clear

Thermostat Protector, Mini with

STI-9102 Thermostat Protector, Small with 1/4 turn lock - clear

STI-9105 Thermostat Protector, Small with key lock - clear

Thermostat Protector, Small with key lock -

STI-9110 Thermostat Protector, Large with key lock - clear

STI-9115 Thermostat Protector, Dome shaped - clear

Accessories:

SUB-900 Clear, 2" Spacer for STI-9110

SUB-901 Clear, 2" Spacer for STI-9105

SUB-905 Clear, 1 1/4" Spacer for STI-9105

19013 #10 x 1 1/2" Phillips pan-head screw for STI-9110

19026 #10 x 2 1/2" Phillips pan-head screw for STI-9110 with SUB-900

WARRANTY

Three year guarantee against breakage of polycarbonate in normal use.

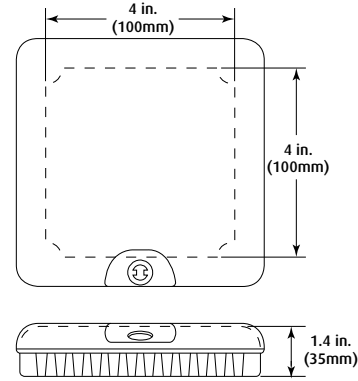

STI-9102

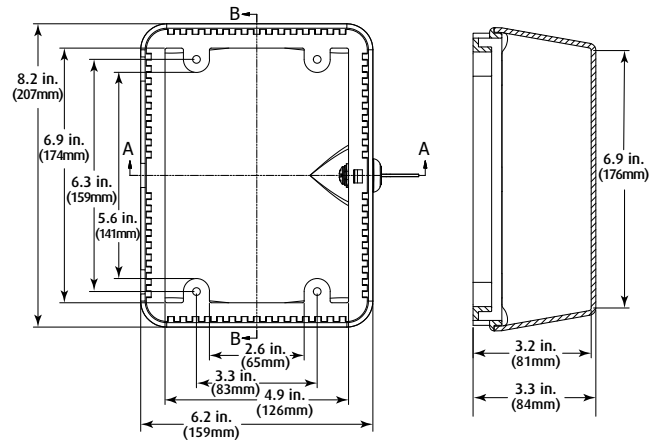

STI-9105

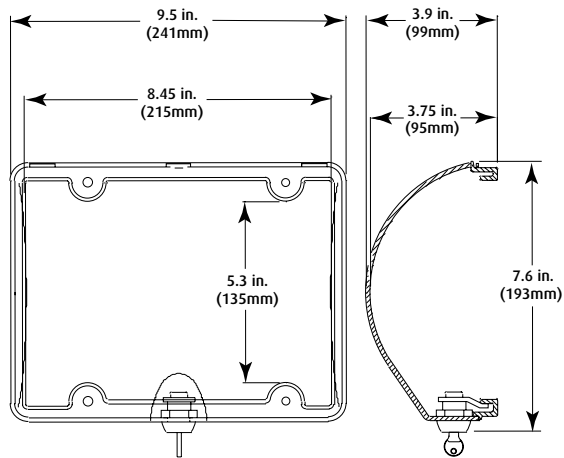

STI-9110

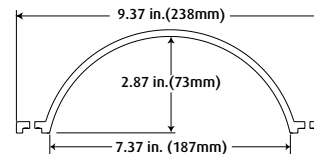

STI-9115



Safety Technology International, Inc.

2306 Airport Road
Waterford, Michigan
48327, USA

Tel: 248-673-9898
Fax: 248-673-1246
Toll-free: 800-888-4784
info@sti-usa.com
www.sti-usa.com

Unit 49G Pipers Road
Park Farm Industrial Estate
Redditch, Worcestershire
B98 0HU England

Tel: 44 (0) 1527 520 999
Fax: 44 (0) 1527 501 999
info@sti-europe.com
www.sti-europe.com